

Ferrolli

NEW
MODEL

WINNER

Packaged unit with heat pump

OZONE SAVED
R410A



>>> DOMESTIC
AIR-CONDITIONING <<<



WINNER BIG only

AIR-CONDITIONER WITHOUT THE OUTDOOR UNIT

Just one air-conditioner has what other products split into two.



- Ecological refrigerant R410A
- Temperature display on the unit
- Removable grill with standard regenerable filters and activated carbon filters
- Automatic reset in the event of power failures
- "AUTOMATIC" mode
- Timer function
- Easy to install

The condensate produced during operation in cooling mode is first piped to the hot exchanger where it evaporates and is then discharged together with the air taken in from the outside. The part that does not evaporate is collected in a basin and can be drained in two ways:

- using a special drain pipe supplied (this requires an additional 30 mm hole)
- by overflowing into the air discharge pipe, suitably sloped down towards the outside.

In heating operation, any condensate that forms on the coil cannot evaporate, therefore one of the two modes described above must be used to drain it.



REMOTE CONTROL DISPLAY

- ▲ AUTO mode - Automatic
- ❄️ COOL mode - Cooling
- 💧 DRY mode - Dehumidification
- ✚ FAN mode - Ventilation
- 🔥 HEAT mode - Heating
- 🌙 Operation in SLEEP mode

88:88 TIMER function

((+)) FAN SPEED indicator

☀️ Select fin position for air flow into the room



Infrared remote control to manage all the functions of the air-conditioner.



Antibacterial filters.



AUTO operating mode, automatically activates Cool/Heat operation based on the room temperature and the set point.



DRY operating mode, brings extra dehumidification in summer.



SLEEP operation, increases comfort at night-time by automatically adjusting the fan speed and the set temperature.



FAN operating mode, activates the fan only on the indoor unit.



SWING function (motorised louver).



Automatic fan speed control.



Settings saved in the memory with automatic restart in the event of power failures.



Timer



All the products are ROHS compatible, in compliance with Directive 2002/95/EC.

		Model	WINNER	WINNER BIG
Power supply		V/Ph/Hz	230 / 1 / 50	230 / 1 / 50
Cooling capacity	(1)	W	2.460	3.200
EER		W/W	2.51	2.41
Total power input in cooling		W	980	1.330
Rated current in cooling		A	4.4	6.0
Dehumidification		l/h	0.8	1.3
Heating capacity	(2)	W	2.750	3.300
COP		W/W	2.90	2.61
Total power input in heating		W	950	1.265
Rated current in heating		A	4.3	5.7
Energy efficiency class according to EC directive 2002/31	cooling heating		B ABCDEFG	B ABCDEFG
Refrigerant			R410A	R410A
Indoor fan air flow-rate		m³/h	400	450
Unit sound pressure	(3) min-max	db(A)	41 - 47	43-50)
Packaging dimensions (WidthxHeightxDepth)		mm	1.220x665x285	1.220x665x285
Net unit weight		kg	40	45

- (1) Outside air temperature = 35°C DB • Ambient air temperature = 27°C DB / 19°C WB
- (2) Outside air temperature = 7°C DB/6°C WB • Ambient air temperature = 20°C DB
- (3) Sound pressure measured at a distance of 1m: O.U. in free field, I.U. in a 100 m³ room with reverberation time of 0.5 seconds

DIMENSIONS

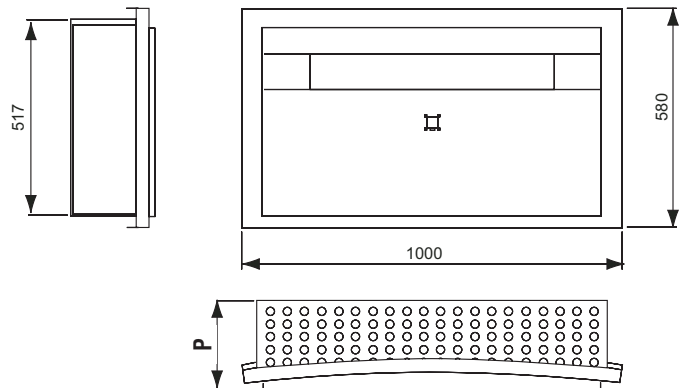
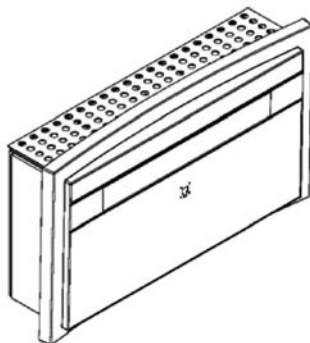

	WINNER	WINNER BIG
P mm	230	245

INSTALLATION PROCEDURE

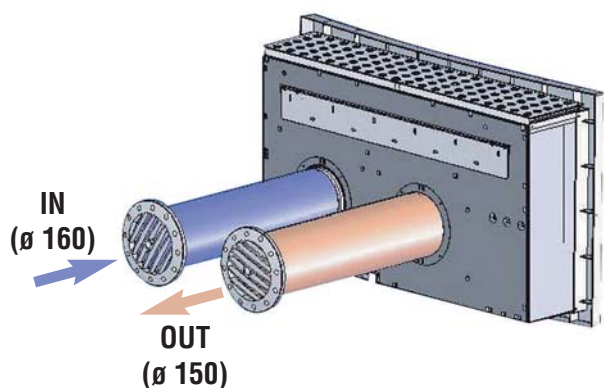
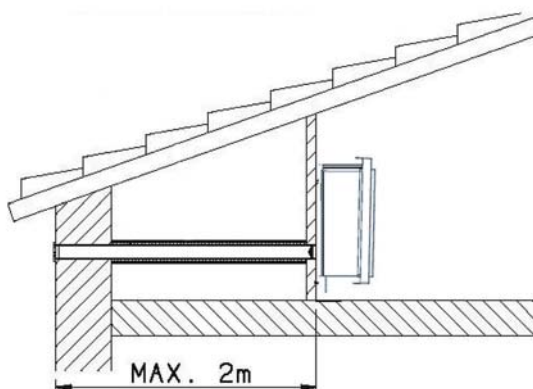

Ferrolì

cod. 0000000000 - 02/09



dpac uk Ltd - Ferrolì Agent for UK
2 The Tramway - Outwell - Wisbech
Cambridgeshire, PE14 8PZ
tel. +44 0845 257 6380 - fax +44 0845 257 6375
simon@dpac.co.uk